

SCREW AND BARREL



地址：江苏省张家港市三兴工业园

Add: Industrial zone, sanxing town, zhangjiagang city, jiangsu Province, China.

国内业务部 (CHINA) :

电话: +86-512-58516595

传真: +86-512-58516596

邮箱: sales@xjgmachine.com

网址: www.xjgmachine.com

INTERNATIONAL DEPARTMENT

TEL/FAX : +86-512-58516595

EMAIL : sales@xjgmachine.com xjgmachine@gmail.com

Web : www.xjgmachine.com

24 Hours Hotline : +86-13962292365 (whatsapp/viber/wechat)



国际品牌的品质与服务

International brand of Excellent performance and service



张家港市青辰雨机械有限公司
ZHANGJIAGANG QING CHEN YU MACHINERY CO.,LTD

产品技术参数 Technical Specification

技术参数	Technical Specification
调质硬度: HB280-320	Hardness After Hardening & Tempering: HB280-320
氮化硬度: HV850-1000	Nitrided Hardness: HV900-1100
氮化层深度: 0.50~0.80mm	Nitrided Case Depth: 0.50~0.80mm
氮化脆性: ≤二级	Nitrided Brittleness: Less Than Grade 2
表面粗糙度: Ra 0.4	Surface Roughness: Ra 0.4
螺杆直线度: 0.015mm	Screw Straightness: 0.015mm
氮化后表面镀铬层硬度: ≥900HV	Surface Chromium-Plating's Hardness After Nitriding: ≥900HV
镀铬层厚度: 0.025~0.10mm	Chromium-plating Depth: 0.025~0.10mm
双合金硬度: HRC50-65	Alloy Hardness:HRC62-66
双合金深度: 2~5mm	Alloy Depth: 2~5mm

材料和工艺	Materials&processes
优质38CrMoAlA(JIS SACM645)	Quality 38CrMoAlA(JIS SACM645)
优质双相不锈钢	Quality Duplex Stainless Steels
42CrMo(JIS SCM440)	42CrMo(JIS SCM440)
40Cr	40Cr
锌3#钢	GH113
SKD11	SKD11
SKD61(H13)	SKD61(H13)
Cr12MoV	Cr12MoV
优质粉末冶金材料	Quality Powder Metallurgy Raw Materials
冷、热喷涂硬金属工艺	Cold/Thermal Spray Hard Metal Process
先进渗氮工艺	Advanced Nitriding Process
耐腐蚀、耐磨双金属喷涂工艺	Corrosion & Abrasion Resistance Bimetallic Spraying Process



CONICAL TWIN SCREW AND BARREL 锥形双螺杆、机筒



规格 Specifications

Φ24/Φ52, Φ35/Φ80, Φ45/Φ90, Φ45/Φ100, Φ50/Φ105, Φ51/Φ105, Φ55/Φ110, Φ55/Φ120, Φ58/Φ124, Φ60/Φ125, Φ65/Φ120, Φ65/Φ132, Φ68/Φ143, Φ70/Φ135, Φ70/Φ140, Φ75/Φ150, Φ80/Φ143, Φ80/Φ156, Φ92/Φ188, Φ105/Φ216, Φ110/Φ220

螺杆压缩比可根据不同的原料及不同的配方进行设计。

The compression ratio of screws can be designed according to different raw material and products.



PARALLEL TWIN SCREW AND BARREL 平行双螺杆、机筒



平行双螺杆、机筒规格：

Parallel twin screw and barrel :

长径比：L/D：18~35

螺杆可根据不同原料及不同产品进行设计。

Ratio (L/D) : 18~35

Could be designed different types according to variety of raw material and products.

规格(specification) : Φ52/2, Φ60/2, Φ65/2, Φ70/2, Φ72/2, Φ75/2, Φ80/2, Φ85/2, Φ90/2, Φ93/2, Φ100/2, Φ105/2, Φ110/2, Φ115/2, Φ120/2, Φ125/2, Φ130/2, Φ140/2, Φ150/2, Φ160/2, Φ170/2, Φ180/2, Φ190/2, Φ200/2, Φ250/2,



SCREW AND BARREL FOR EXTRUDER 挤出机螺杆、机筒



规格 Specification

螺杆直径 Screw Diameter: $\text{Ø}15\sim\text{Ø}300$

长径比 Length/Diameter Ratio: 7~55

螺杆可选用普通型、渐变型、突变型、屏障型、销钉型、分离型、排气型等。

Screws can be selected from ordinary, gradual, mutational, pinned, separating and exhausting types.

螺杆压缩比可根据不同的原料设计，也可按照用户要求进行设计。

The compression ratio of screws can be designed according to different raw materials and requirement of clients.



SCREW AND BARREL FOR INJECTION MACHINE 注塑机螺杆、机筒



规格 Specification

螺杆直径 Screw Diameter: $\text{Ø}20\sim\text{Ø}220$

锁模力 Mould Clamping Force: 100~35000KN

注塑量 Shot weight: 30~30000G

螺杆可选用不同的螺杆头，机筒可选用相应的喷嘴。

Screw can be matched with different heads, and barrel can be matched with different nozzles.



GEARBOX 齿轮箱

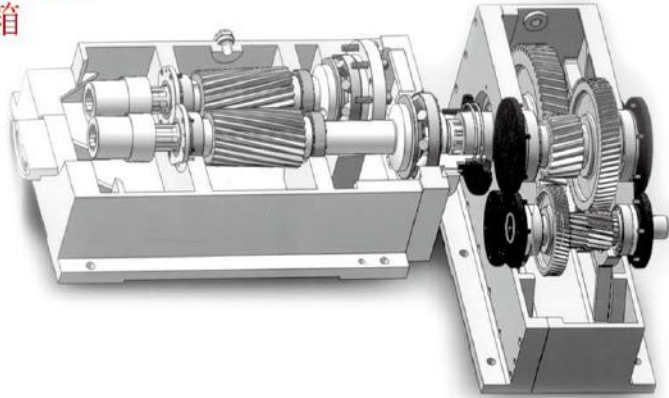

单螺杆挤出机减速机 (选购) 推荐参数

Recommended parameters of reduction gearboxes for single-screw extrusion machine

型号Type	规格Spec	输入功率Kw	n入	n出	输出扭矩 N.m Torque	输出轴轴向推力KN Axial thrust	螺杆直径 Screw diameter	长径比 Length-diameter ratio
ZLYJ	112-8	5.5	800	100	525	35	≤Φ35	25:1
	133-8	8	800	100	764	39	≤Φ50	25:1
	146-10	11	1000	100	1050	54	≤Φ55	25:1
	173-10	18.5	900	90	1962	110	≤Φ65	25:1
	200-12.5	30	1000	80	3581	155	≤Φ75	25:1
	225-12.5	45	1000	80	5371	180	≤Φ90	25:1
	250-16	55	1120	70	7503	192	≤Φ105	25:1
	280-16	75	960	60	7643	258	≤Φ110	25:1
	315-16	85	960	60	13528	287	≤Φ120	25:1
	330-16	110	960	60	17507	360	≤Φ135	25:1
	375-16	132	960	60	21008	390	≤Φ150	25:1
	395-16	185	960	60	29442	400	≤Φ160	25:1
	420-16	160 220	960	60	31831	430	≤Φ160 ≤Φ170	25:1
	450-20	213	1000	60	40640	500	≤Φ180	25:1
	560-17	440	1000	50	84034	700	≤Φ200	25:1
630-10	540	1000	50	103132	770	≤Φ250	25:1	
ZSYJ	450-32	200	1500	47	40635	500	≤Φ165	25:1
	560-57	220	1500	26	80802	700	≤Φ190	25:1
	630-44	315	1500	34	88471	770	≤Φ200	25:1

BIMETALLIC SCREW AND BARREL 双金属螺杆和机筒

product category: bimetallic hole centrifugal casting barrel
 Processing Range: inner diameter 15mm-500mm, effective length:8000mm
 Processing Technology: HP/HVOF+Metallurgical Bonding
 alloying component : Ni+Cr+Wc etc.
 Hardness: HRC62-66
 adhesion power:≥126MPa
 straightness:0.015mm/m
 surface roughness: Ra0.4um
 Alloy nameplate:Sweden
 Product note: Patent all alloy sintering technology, super wear resistance, super corrosion resistance, suitable for halogen free material

